

The Summer Festival of Bridge

Daily Bulletin 6

Monday January 19 2015

Welcome

To the South West Pacific Teams Championship

Over the next four days, some 130 teams will be competing for prizes, gold points and glory in this prestigious event.

Don't forget to complete and to lodge your Category Self-nomination forms as first and second in each of the categories (excluding the first qualifying) will play a 32 board final on Friday. Forms are available in the playing area.

Categories are:

- Women
- Youth
- Mixed
- Men
- Seniors
- Country

At the conclusion of the event the winning team will receive a cheque for \$250 (Please note: all prizes quoted are for the team, not the individual team members.)

The overall winning team, at the end of day 4, will receive a cheque for \$1000 and a Derofe pen and wine for each team member.

The National Teams Championship will be on the 23rd to 25th of January. The winning team receives \$2500 and the runners-up will receive \$1000.

The highest placed eligible team will receive an ABF subsidy (and the entry fee) to represent Australia at the Yeh Cup being held in China in April 2015.

Happy bridging and good luck everyone.



Tim Bourke's Problem

6. FINESSE

Dealer West. Neither Vul.

NORTH

- ♠ J 6 3
- ♥ K Q 8 6
- ♦ A J 7 5
- ♣ Q 2

SOUTH

- ♠ A Q 2
- ♥ A J 10 7 4
- ♦ Q 6
- ♣ 9 8 3

| West | North | East | South |
|----------|-------|------|-------|
| Pass | 1♦ | Pass | 1♥ |
| Pass | 2♥ | Pass | 4♥ |
| All pass | | | |

West cashes the ace and king of clubs before switching to a trump. You play low from dummy and East follows suit with the nine. After winning the first trick with the ten of trumps, how do you plan to make ten tricks?

Items for the Bulletin can be left at the Festival desk or can be emailed to

alan@tayl0rs.co.nz

The 0 is a zero not a letter

Requests for photos from this or any

Other Bulletin can be sent to the same email address.



TherapyMasters
Caring for you and your body

Refreshing on-site massage available in the afternoon

- Tuesday 20 January
- Thursday 22 January

Bookings: Information Desk, Mezzanine Floor



Free SFOB App 2015

- You can *register* for competitions using the app this year !
- Look up results / entries / festival program



Tim Bourke's Problem

SOLUTION

The layout you want to overcome is one similar to this:

| | | |
|------------|--------------|------------|
| | ♠ J 6 3 | |
| | ♥ K Q 8 6 | |
| | ♦ A J 7 5 | |
| | ♣ Q 2 | |
| ♠ K 9 8 | | ♠ 10 7 5 4 |
| ♥ 5 3 2 | | ♥ 9 |
| ♦ 9 4 3 | | ♦ K 10 8 2 |
| ♣ A K 10 7 | | ♣ J 6 5 4 |
| | ♠ A Q 2 | |
| | ♥ A J 10 7 4 | |
| | ♦ Q 6 | |
| | ♣ 9 8 3 | |

Suppose you draw trumps and run the queen of diamonds. When this loses to East's king, you will have only one spade discard on dummy's diamonds and making the contract will rely on the spade finesse to win. On the above deal that approach would restrict you to nine tricks.

The best line is to draw a second round of trumps with dummy's queen and then lead a low diamond towards your hand. Barring a defensive ruff, this will make the contract whenever East started with the king of diamonds. (If East rises with the king, you will have three diamond tricks and the entries to take them. If instead East plays low, you will not lose a diamond trick and then you can happily withstand the loss of a trick to the king of spades.) When the lie of the cards is similar to that above, the defence has no counter that prevents you from taking ten tricks.

Notice that drawing a third round of trumps and the leading a low diamond would enable East rise with the king of diamonds and force dummy with a club, thereby preventing you from untangling your diamond winners.

The last question to ask is "What would happen if the queen of diamonds lost to the king with West?"

Luckily, that would mark West with ten high card points and, since he failed to open the bidding, the king of spades with East! As a result, after drawing trumps, you would be able to discard one spade loser on a diamond winner and then take the known-to-be successful finesse in spades.

An Inevitable Score

Michael Courtney

Those who recall their Doctor Who will be aware of the temporal paradox. On Saturday Doctor Ong finally tested his time machine only to discover that the theory was true...

Bd.17 Match 6 Swiss Pairs

| | | | | | | | | | | | | | | | | | | | | | | | | | | | | | | | | |
|-----------------------------------|-----------------------------------|---|---|---|----|---|---|----|---|---|---|---|---|---|---|---|---|---|---|---|---|---|---|---|---|---|---|---|---|---|---|---|
| 17 | ♠ KQ84 ♥ Q843 ♦ 987 ♣ 92 | Dir: N Vul: None | | | | | | | | | | | | | | | | | | | | | | | | | | | | | | |
| ♠ 9 ♥ K976 ♦ KQJ62 ♣ A87 | ♠ A763 ♥ AJT ♦ A4 ♣ KQ65 | | | | | | | | | | | | | | | | | | | | | | | | | | | | | | | |
| 7 13 18 2 | ♠ JT52 ♥ 52 ♦ T53 ♣ JT43 | <table border="1" style="border-collapse: collapse; font-size: small;"> <tr> <td></td> <td>♠</td> <td>♥</td> <td>♦</td> <td>♣</td> <td>NT</td> </tr> <tr> <td>N</td> <td>-</td> <td>-</td> <td>-</td> <td>-</td> <td>-</td> </tr> <tr> <td>S</td> <td>-</td> <td>-</td> <td>-</td> <td>-</td> <td>-</td> </tr> <tr> <td>E</td> <td>6</td> <td>7</td> <td>6</td> <td>3</td> <td>6</td> </tr> <tr> <td>W</td> <td>6</td> <td>7</td> <td>6</td> <td>3</td> <td>6</td> </tr> </table> | | ♠ | ♥ | ♦ | ♣ | NT | N | - | - | - | - | - | S | - | - | - | - | - | E | 6 | 7 | 6 | 3 | 6 | W | 6 | 7 | 6 | 3 | 6 |
| | ♠ | ♥ | ♦ | ♣ | NT | | | | | | | | | | | | | | | | | | | | | | | | | | | |
| N | - | - | - | - | - | | | | | | | | | | | | | | | | | | | | | | | | | | | |
| S | - | - | - | - | - | | | | | | | | | | | | | | | | | | | | | | | | | | | |
| E | 6 | 7 | 6 | 3 | 6 | | | | | | | | | | | | | | | | | | | | | | | | | | | |
| W | 6 | 7 | 6 | 3 | 6 | | | | | | | | | | | | | | | | | | | | | | | | | | | |



| West T. Ong | North | East M Courtney | South |
|----------------|-------|--------------------|-------|
| | | 1♣ | P |
| 1♠ | P | XX | P |
| 2♥ | P | 2♠ | P |
| 3♣ | P | 6♣ | End |

One club required transfer responses as required by current fashion. One Spade showed diamonds. Re-double was an offer to see that contract played. Two hearts showed sound opening values with four hearts and longer diamonds; three clubs completed the picture 1453 12+.

To cater for a South hand like Jxx xx Jxxx Jxxx I tried six clubs. Ruffing in the short hand produces extra tricks. Six clubs was certain unless clubs were 5-1 or 6-0. Since our diamonds are solid the best spot is 6D; it will make seven if declarer guesses the heart queen.

So we made 920.

At dinner we discussed the auction and Tony opined that it was time to test the dread device. After all we had a good score on the board anyway.. No argument could dissuade him and directly he disappeared from view.

This time Tony had a different auction

| West T. Ong | North | East M Courtney | South |
|----------------|-------|--------------------|-------|
| | | 1♣ | P |
| 1♠ | P | XX | End |

Wild stuff, the known 4-1 fit. The defence did double dummy perfect by leading clubs and taking the club ruff. Thus they took four tricks. 1Sxx +2 was worth 920.

Presumably this means that if you travel to before your father was conceived and kill

your grandfather then your father was a bastard all the time.

Pressure Play

NZ international player, Wayne Burrows, brings us both sides of squeeze play – subjecting as declarer and suffering as defender. First up a remarkable three suit guard squeeze.

Wayne declared 3NT from South.

A club was led to the Ace and the ♣J was allowed to stand at trick 2. Wayne took the ♣9 which followed with the King and cashed a high diamond. The ♠A came next, followed by a spade to the King, dropping the Queen. Two more high diamonds followed to bring about:

When Wayne advanced the $\heartsuit 10$, East had all sorts of problems.

If he discards a club, then Wayne will score a club, a diamond, two hearts and a spade.

If he discards a spade then Wayne will score two spades, two hearts and a diamond.

So he discarded a heart and now Wayne scores his spade, diamond and three hearts by finessing against East's now vulnerable Queen.

And the obverse:

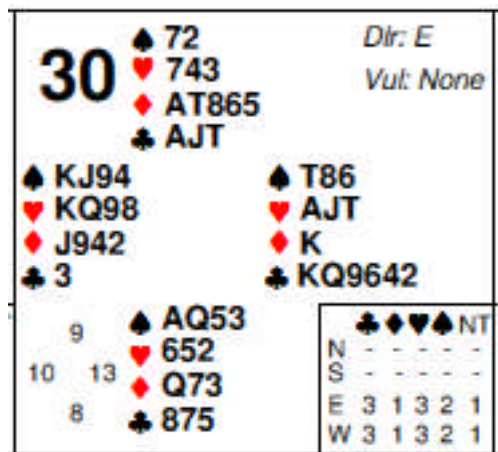
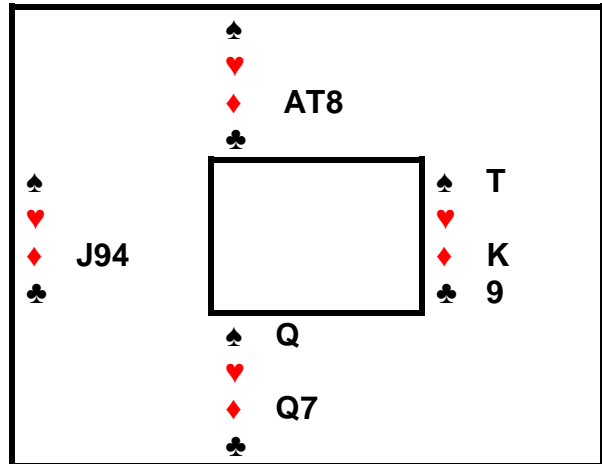

West was playing 3NT and North led the $\heartsuit 7$, overtaking dummy's 10 with the King. A club was played to dummy's King and the $\clubsuit Q$ was taken by North, while declarer discarded a spade.

North exited with a heart, taken on table with the Jack and a club was conceded to North's Jack. North switched to a spade to Wayne's Ace and he continued spades to declarer's King. Declarer crossed to dummy via the $\heartsuit A$ and started cashing clubs. With one to go, the position was:

If Wayne pitches a spade then declarer will just concede trick 13 but pitching a diamond is no better as the $\heartsuit K$ then pins Wayne's Queen and North has to yield trick 13 to the $\heartsuit J$.

Quite Interesting History of Bridge

Richard Hills

The usual rules apply to this quite interesting quiz on the history of bridge. A boringly obvious but incorrect answer will be highlighted in BLOCK CAPITALS accompanied by the sound of a klaxon!!! And each contestant will have a "Nobody Knows" joker to be used on the question to which nobody knows the answer.

The usual rules apply to this quite interesting quiz on the history of bridge. A boringly obvious but incorrect answer will be highlighted in BLOCK CAPITALS accompanied by the sound of a klaxon!!! And each contestant will have a "Nobody Knows" joker to be used on the question to which nobody knows the answer.

- 1) What is the title of the pamphlet in the British Museum which is believed to describe the ultimate ancestor of Contract Bridge?

Humorous but wrong answers = 1 point



AUCTION BRIDGE = klaxon!!! = minus 10 points
 Biritch, or Russian Whist = correct = 5 points

- 2) Auction Bridge was modified into Contract Bridge by whom?

Humorous but wrong answers = 1 point
 ELY CULBERTSON = klaxon!!! = minus 10 points. Ely Culbertson was the great populariser of Bridge in the 1930s via his Blue Book (and its sequels) and via such publicity stunts as the Match of the Century, but the game was invented by Harold Vanderbilt = correct = 5 points. However when Contract Bridge was invented by Harold Vanderbilt in 1925 similar card games existed elsewhere in the world, for example the French card game of Plafond.

- 3) What was the name of the person who suggested to Harold Vanderbilt that he incorporate the concept of "vulnerable and not vulnerable" into his new game?

Humorous but wrong answers = 1 point
 Nobody Knows = correct = 5 points. In yet another example of sexism in history, Harold Vanderbilt merely stated that she was a young woman.

- 4) What is the single fundamental difference which makes Contract Bridge a greater test of skill than its predecessor Auction Bridge?

Humorous but wrong answers = 1 point
 VULNERABILITY = klaxon!!! = minus 10 points. Although vulnerability does apply to Contract Bridge and not to Auction Bridge, it is not the single fundamental skillful difference.

Must bid game to get the game bonus (and must bid slam to get the slam bonus) = correct = 5 points. In Auction Bridge if you bought the contract in 1H and scored ten tricks you automatically gained the game bonus (and if you scored twelve tricks you

automatically gained the small slam bonus). In Contract Bridge you need to learn and correct apply more sophisticated bidding systems to arrive at the right level.

(more to follow)

Australian Youth Championships

The 47th Australian Youth Bridge Championships took place at Bruce Hall at the Australian National University last week with a playoff for the third berth for the 2015 Australian Under-25 team together with a youth test match between Australia and New Zealand for the Stern-Cornell Trophy concluding at QT Canberra on Saturday.

The major title winners were:

Youth Pairs: Shane Harrison & Max Henbest.

Youth Teams: Nabil Edgtton, Daniel Braun, Jamie Thompson & Stephen Williams.

Youth Butler: 1st: Jamie Thompson & Stephen Williams;
 2nd Shane Harrison & Max Henbest;
 3rd Renee Cooper & Ella Pattison.

Youth Test: Australia (Jamie Thompson, Stephen Williams, Shane Harrison & Max Henbest) 155 - New Zealand (Andi Boughey, Glenn Coutts, Sam Coutts & Orla Harris) 100.

The Final Act

The National Seniors' Teams went right down to the wire. Can you win the event for your team?

You hold at vul against not:

♠J862 ♥8 ♦AJ10952 ♣A3

You (West) pass as dealer. North opens 1♥ and partner doubles. South responds 4♥ and it's your call.



getwinesdirect.com



This was the problem faced by David Lilley on the very last board of the Seniors' final. David's team were ahead by 6 and as the board landed the BBO commentator said that the Neill team (of which David is a member) were in the box seat as in the other room, NS had been allowed to play 4♥x for – 300 with 600 available to EW in 5♦. The commentator added “unless something strange happens”.

Something strange did –

26

Dir: E
Vul: Both

♠ KJT763
♥ J94
♦ J98
♣ 6

♠ AQ84
♥ 62
♦ A632
♣ QT5

♠ 9
♥ AQT753
♦ 7
♣ AKJ84

6 ♠ 52
12 14 ♥ K8
8 ♦ KQT54
♣ 9732

| | |
|---|-----------|
| ♠ | NT |
| N | - - - 1 - |
| S | - - - 1 - |
| E | 6 - 5 - 2 |
| W | 6 - 5 - 2 |

In play against Peter Gill and Paul Dalley, the auction was

32

Dir: W
Vul: E-W

♠ A975
♥ KQ743
♦ 87
♣ QJ

♠ J862
♥ 8
♦ AJ10952
♣ A3

♠ Q3
♥ A5
♦ KQ64
♣ K10962

12 ♠ K104
10 14 ♥ J10962
4 ♦ 3
♣ 8754

| | | | | |
|---|-----------|---|---|----|
| ♠ | ♦ | ♥ | ♣ | NT |
| N | - - 2 - - | | | |
| S | - - 2 - - | | | |
| E | 5 5 - 1 5 | | | |
| W | 5 5 - 1 5 | | | |

| West Peter | North Mike | East Paul | South Ash |
|---------------|---------------|--------------|--------------|
| | | 1♥ | P |
| 1♠ | P | 3♣ | P |
| 3♦ | P | 3♥ | P |
| 4♣ | P | 4♦ | x |
| 4♥ | P | 4NT | P |
| 5NT | P | 6♣ | End |

David called 4♠ and there it rested. He really did have nowhere to go for honey and 3 down meant that the Brown team had reversed the margin from -6 imps to +6 imps and won the National Seniors' Teams.

Paul won the diamond lead, cashed the ♥A and gave up a heart. He ruffed the diamond continuation, ruffed a heart with dummy's ♣Q and claimed.

Another combination falling at the last hurdle were Ashley Bach and Mike Cornell. They had squatter's rights on NS at table 1 for almost the whole of the Swiss. They finally lost in round 10 (of 11) but were still ensconced for the last round. It was not a happy time and this was the last act.

Meanwhile, Pauline Gunby and Warren Lazer had been chasing Bach/Cornell for two days. They faced this auction

VISIT

RonKlingerBridge.com
IMPROVE YOUR GAME

for articles, teaching resources and books

| West | North | East | South |
|------|-------|------|-------|
| | | 1♥ | P |
| 1♠ | P | 2♣ | P |
| 2♦ | P | 3♣ | P |
| 3♥ | P | 4NT | P |
| 5♣ | P | 6♣ | P |
| 6♥ | End | | |

The offer to play 6♣ gave Warren, sitting North, on lead, a hefty hint to lead a club. In with the trump King, he led another club for Pauline to ruff.

-8 to Bach/Cornell but +11 to Gunby/Lazer who took the title.

Mike did enjoy one hand from the last set though he probably didn't enjoy the auction.

He held:

♠643 ♥K85 ♦732 ♣10832

Peter opened 2♥ on his left and Mike passed, as did Paul. Ash doubled and Mike had to find a bid. Reluctant to commit to the three level on 10832, he tried 2♠ and was, no doubt, delighted when Ash raised him to game.

| | | | | | |
|-----------|--|---------|--|-------------|--|
| 24 | | ♠ 643 | | Dir: W | |
| | | ♥ K85 | | Vul: None | |
| | | ♦ 732 | | | |
| | | ♣ T832 | | | |
| ♠ 87 | | ♠ A52 | | | |
| ♥ QJT76 | | ♥ 2 | | | |
| ♦ QJ84 | | ♦ T965 | | | |
| ♣ K4 | | ♣ QJ975 | | | |
| 3 | | ♠ KQJT9 | | ♣♦♥♠NT | |
| 9 7 | | ♥ A943 | | N - - 2 3 3 | |
| 21 | | ♦ AK | | S - - 2 4 3 | |
| | | ♣ A6 | | E - 2 - - - | |
| | | | | W - 2 - - - | |

A heart was led to the King in the North hand. Mike played two rounds of trumps, Paul taking the second. He switched to a club and Mike won with dummy's Ace. He cashed a high trump and then exited with a club to Paul. Paul played a diamond to Ace to produce

Mike continued with the ♠J on which Peter pitched a diamond. The spade ten then left Peter with a choice of suicide means.

If he pitched a second diamond, Michael would cash the ♦K and then lead a heart towards the 8 in his hand – endplaying Peter in hearts.

If instead, Peter discarded a heart, Mike would lead a heart and then take the last three tricks with two hearts and a diamond.

Fairly unusual, I think, Peter was not so much squeezed out a trick but rather out of a defensive riposte.



Ash and Mike in play against visitors from Mumbai, Ranjeev and Himani Khandelwal. Ash obviously can't bear to watch Mike lead.

Not Peeing On The Electric Fence

Leigh Matheson

Ed: I love apposite quotations. Of all quotations, probably my favourite is from Will Rogers – "There are three kinds of men. The one that learns by reading. The few who learn by observation. The rest of them have to pee on the electric fence for themselves"

| | | | | | |
|-------|--|-------|--|-------|--|
| | | ♠ | | | |
| | | ♥ 85 | | | |
| | | ♦ 73 | | | |
| | | ♣ T3 | | | |
| ♠ QJ7 | | | | ♠ | |
| ♥ QJ8 | | | | ♥ | |
| ♦ QJ8 | | | | ♦ T96 | |
| ♣ | | | | ♣ J75 | |
| | | ♠ JT | | | |
| | | ♥ A94 | | | |
| | | ♦ K | | | |
| | | ♣ | | | |

Leigh submitted the following hands and, on reading his material, it became apparent that Leigh belongs to Will Hay's category 1. Hereinafter, all italicised comments are mine (the italics probably caused by electric shock.). The stuff in plaintext and which makes sense is Leigh's. All the hands relate to the first day of the Swiss.

I believe that the term "Intra-finesse" was introduced into the bridge vocabulary in an early Bols Tip from Gabriel Chagas.

I was one of several declarers who found the right play on this one from round 1 of the Swiss.

I was in 3NT. How should I play the club suit to the best advantage?

The answer is to start by leading the ♣3 towards dummy. If North plays the 10, you cover with the Jack and South wins. On the next round, you play the ♣A, dropping the Queen.

When I led the ♣3, North, in fact, jumped in with the Queen. Later, I got to dummy and led the ♣J, pinning North's 10.

I'm reasonably sure that one of the most appreciated early Bols Tips was from Jeff Rubens. Jeff recommended that you should

cosset your partner. Leigh demonstrates, once again, his allergy to electrocution.

Richard Grenside produced a very thoughtful defence on this one from round 2 of the Swiss.

The auction was:

| West | North | East | South |
|------|-------|------|-------|
| 1♦ | 3♠ | P | P |
| 3NT | End | | |

The ♠10 was led, losing to declarer's Jack. A diamond was played to the Queen and then a club to the 7 and 9. Richard "exited" with the ♥Q, only to find that he'd won the trick. Trying again, this time successfully, he exited with a diamond to declarer's Ace. A diamond was played to dummy's Jack and a heart played off dummy. South chose to play low and declarer won the ♥K. Declarer then cashed the top diamond and club before putting Richard on lead with the ♠8. The layout had become:

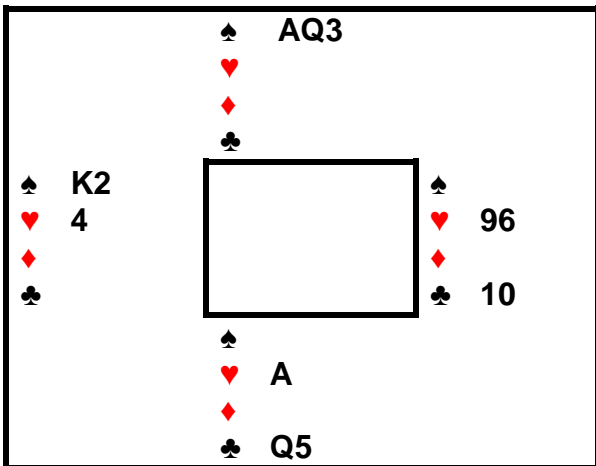

Many defenders would cash the ♠A and then exit with a spade. This inflicts a memory squeeze on South who needs to be paying close attention to get it right. Richard, recognising the situation, exited with the ♠3, gaining style points, without cashing the top spade. Now South could keep the top heart and top club without getting squeezed so one down.

Back to Leigh

A good defender will try to envisage partner's problems and take active steps to solve them.

Is there anyone except me who finds "The Rodwell Files" totally unreadable? Is there anyone except me who hates Rodwell's habit of attaching a soubriquet to every single play situation?

Ho hum, minority of one again, I guess. Back to Leigh.

One of the most recent additions to my bridge armoury is what Eric Rodwell calls "the Left Jab". (For more detail read "The Rodwell Files' – go on I dare you!")

I had an opportunity to use it in Round 3.

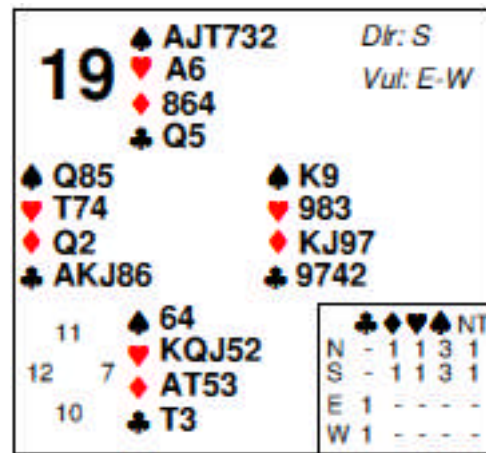

| West | North | East | South |
|-----------|-------|------|---------|
| 1♣ End | 1♠ | P | P 2♥ |

Against 2♥, I led the ♣A and switched to a trump, in case declarer had a third club to ruff in dummy. Declarer won with dummy's Ace and played a diamond to the 10 and my Queen. I returned another trump and declarer drew trumps to then lead spade on this layout:

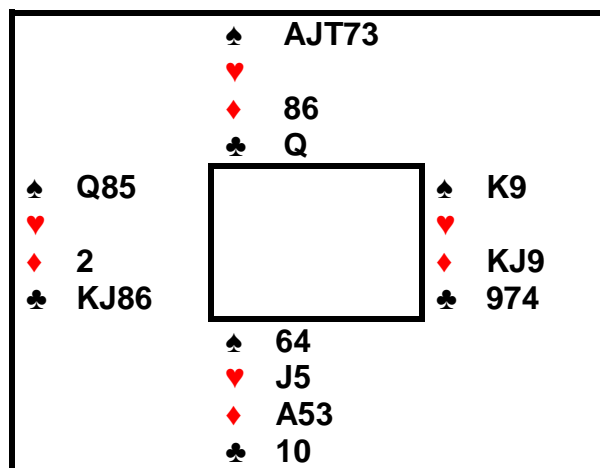

When declarer led the ♠4, I followed with the Queen (left jab!). Declarer won with the Ace and now there was no way to set up and enjoy the spade suit. One down.

You can see what happens if I had followed suit with a low spade. Declarer would

finesse and later finesse again to establish spades and make at least one overtrick.

Rodwell's book gives the following advice, "Don't use the left jab from honour third versus a 6-2 fit, count on partner to duck with honour doubleton onside. It's true that this defence will also kill the suit but, on this deal, it will give declarer the one extra trick to make the contract. The only chance on this deal is to use the left jab and hope that declarer doesn't counter it by ducking the ♠Q and then playing the ♠A on the next round, dropping the ♠K - a difficult line of play to find. Perhaps this chapter of Rodwell's book needs editing.

This illustrates one of my issues with TRF – I understand why the Merrimac, Dechappelles, Vienna Coups, Morton Forks etc are called as they are and so with most bridge terms but Left Jab????????? Back to Leigh for a totally comprehensible piece of nomenclature.

Richard McAuliffe found a neat play on this one:

| | | |
|-------------|-------------|----------|
| 16 | ♠ A6 | Dir: W |
| | ♥ 8432 | Vut: E-W |
| | ♦ AKT98 | |
| | ♣ J2 | |
| ♠ K8 | ♠ Q74 | |
| ♥ AT9 | ♥ K75 | |
| ♦ J4 | ♦ Q632 | |
| ♣ AQT984 | ♣ 765 | |
| 12 ♠ JT9532 | ♣♦♥♠ NT | |
| 14 7 ♥ QJ6 | N - 1 - 1 - | |
| 7 ♦ 75 | S - 1 - 1 - | |
| ♣ K3 | E 3 - 1 - 3 | |
| | W 3 - 1 - 3 | |

West played in 3♣. I was North and cashed the two top diamonds and the top spade, South discouraging. I then reverted to diamonds and Richard ruffed with the King to uppercut West's AQ and give the defence a trump trick to hold declarer to 9 tricks.



To access:

- **Choose QT Guest**
- **Password =**
Canberra
(must be C not c)



Tea/Coffee to the table
Just call a caddy and have
money available

TBIB National Open Swiss Pairs Championship

| Place | Pair Names | VPs |
|-------|---|--------|
| | 1 WARREN LAZER / PAULINE GUMBY (4) | 160.35 |
| | 2 GEO TISLEVOLL / JOAN BUTTS (11) | 155.59 |
| | 3 MIKE CORNELL / ASHLEY BACH (3) | 151.93 |
| | 4 MIKE DOECKE / WILLIAM JENNER-O'SHEA (16) | 143.83 |
| | 5 PAUL DALLEY / PETER GILL (6) | 143.77 |
| | 6 ROBERT TYSON / JANE TYSON (83) | 142.1 |
| | 7 LISA MA / NIEK VAN VUCHT (88) | 140.8 |
| | 8 WITOLD CHYLEWSKI (JUN) / LINDA AUBUSSON (102) | 140.71 |
| | 9 ANDREW HIRST / BILL HIRST (202) | 139.31 |
| | 10 RANJIT LIMAYE / MICHAEL DRAPER (66) | 139.18 |
| | 11 TIM MUNRO / MICHAEL GEARING (201) | 139.05 |
| | 12 KIM FRAZER / CATHERINE LACHMAN (71) | 138.3 |
| | 13 MICHAEL PEMBERTON / GRAHAM WAKEFIELD (36) | 137.73 |
| | 14 RANJEEV KHANDELWAL / HIMANI KHANDELWAL (29) | 137.67 |
| | 15 ROY NIXON / BERNARD WATERS (37) | 137.19 |
| | 16 GARY LYNN / ERIC HURLEY (80) | 135.86 |
| | 17 NICK JACOB / JAMES COUTTS (28) | 135.59 |
| | 18 MATTHEW THOMSON / PAUL GOSNEY (2) | 135.53 |
| | 19 CAROL RICHARDSON / STEVE BOUGHEY (19) | 134.41 |
| | 20 JOHN NEWMAN / SEBASTIAN YUEN (21) | 134.12 |
| | 21 MARK JAPPE / JOHN MADDISON (20) | 132.29 |
| | 22 DAVID PRIOL / PETER LAMEKS (78) | 131.44 |
| | 23 ROGER JANUSZKE / JOHN ZOLLO (27) | 131.42 |
| | 24 MAURA RHODES / RICK RHODES (94) | 131.21 |
| | 25 GABI LORENTZ / STEPHEN BURGESS (1) | 130.99 |
| | 26 EMLYN WILLIAMS / VAL BROCKWELL (91) | 130.97 |
| | 27 HELENA DAWSON / DAVID WESTON (13) | 129.35 |
| | 28 MALCOLM CARTER / TONY HUTTON (31) | 128.95 |
| | 29 MICHAEL CARTMELL / STEPHEN FISCHER (15) | 128.88 |
| | 30 JUNE GLENN / ALAN HAMILTON (163) | 127.42 |
| | 31 BILL NASH / JAMES WALLIS (41) | 127.22 |
| | 32 STEPHEN MENDICK / ANDREW CREET (48) | 126.48 |
| | 33 EVA SAMUEL / JEFF FUST (64) | 126.33 |
| | 34 TONY LEIBOWITZ / PAUL LAVINGS (22) | 125.87 |
| | 35 TREVOR BERENGER / PERELLE SCALES (169) | 125.39 |
| 35= | RICHARD MOSS / ARENDINA DRURY (124) | 125.39 |
| | 37 DONG CHEN HUANG / SHIJUN TIAN (200) | 125.12 |
| | 38 PETER JEFFERY / ROBERT SEBESFI (63) | 124.82 |
| | 39 MICHAEL COURTNEY / TONY ONG (5) | 124.19 |
| | 40 JANE DAWSON / KIERAN DYKE (12) | 124.13 |
| | 41 LEWIS SEYCHELL / COLIN MANLEY (142) | 123.51 |
| 41= | RICHARD MCAULIFFE / LEIGH MATHESON (193) | 123.51 |
| | 43 JOHN BROCKWELL / TONY JACKMAN (44) | 122.99 |
| | 44 JACK FEILER / BERNARD EDELSTEIN (133) | 122.97 |
| | 45 IAN MCKINNON / DENISE MCKINNON (58) | 122.95 |
| | 46 DEE HARLEY / STEPHEN WEISZ (39) | 122.76 |

| | |
|--|--------|
| 47 JUDITH CRAFTI / PENNY CORRIGAN (120) | 122.31 |
| 48 KEN STORR / PHAIK YAO (76) | 122.21 |
| 49 THEO MANGOS / GEORGE FINIKIOTIS (55) | 122.03 |
| 50 ISHMAEL DEL'MONTE / JOE BARDA (8) | 121.54 |
| 51 MARILYN CHADWICK / TONI SHARP (56) | 121.46 |
| 52 SUE INGHAM / LIAM MILNE (7) | 121.29 |
| 53 JULIAN FOSTER / JENNA GIBBONS (35) | 121.16 |
| 54 EVA CAPLAN / JUDITH GASPAR (46) | 120.89 |
| 55 TRISH THATCHER / AMBER NOONAN (168) | 120.88 |
| 56 DENNIS ZINES / TOM MOSS (32) | 120.58 |
| 57 ANDREW PEAKE / ELIZABETH ADAMS (25) | 120.35 |
| 58 ELLI URBACH / LES VARADI (42) | 120.19 |
| 59 GEORGE BILSKI / NICKY STRASSER (50) | 119.93 |
| 60 MAUREEN JAKES / DIANNE MARLER (67) | 119.76 |
| 61 KEVIN STEFFENSEN / NEVILLE FRANCIS (47) | 119.4 |
| 62 NOEL BUGEIA / ERIC GLASS (129) | 119.02 |
| 63 IAN LISLE / VICKY LISLE (130) | 118.43 |
| 64 MARJORIE ASKEW / WILLIAM POWELL (65) | 118.41 |
| 65 WAYNE SMITH / GRANT COWEN (38) | 118.38 |
| 66 GARRY KHEMKA / DAVID WAWN (40) | 118.37 |
| 67 LEX BOURKE / JOHN TREDREA (115) | 118.32 |
| 68 PETER GRANT / TONY MARINOS (61) | 118.28 |
| 69 TIM DAVIS / STEPHEN CARTER (69) | 118.19 |
| 70 LYNN KALMIN / LORNA ICHILCIK (54) | 117.52 |
| 71 BEN CHOSID / CHRISTY GEROMBOUX (117) | 117.21 |
| 72 MARLENE WATTS / MICHAEL PRESCOTT (9) | 116.88 |
| 73 CATHERINE ZHANG / CEVAT EMUL (23) | 116.77 |
| 74 WALTER KOOCHER / MP FANNING (197) | 116.73 |
| 75 STEVE BARON / JULIAN ABEL (95) | 116.66 |
| 76 ANNETTE MALUISH / HUGH GROSVENOR (10) | 116.14 |
| 77 PRUDIE WAGNER / FELICITY GUNNER (141) | 115.04 |
| 78 JILL MAGEE / TERRY STRONG (51) | 114.97 |
| 79 RICHARD GRENSIDE / SUE GRENSIDE (77) | 114.79 |
| 80 WENDY ASHTON / TONY NUNN (17) | 114.78 |
| 81 MARGARET KLASSEN / BIJAN ASSAEE (111) | 114.67 |
| 82 JENNY HOFF / KIM HOFF (190) | 114.6 |
| 83 PAUL WEAVER / TERRY BODYCOTE (108) | 114.54 |
| 84 JUSTIN HOWARD / RON SPEISER (18) | 113.85 |
| 85 TONY WRIGHT / ALAN WATKINS (183) | 113.78 |
| 86 IAN DALZIELL / TERRY HEMING (180) | 113.56 |
| 87 SUSAN CROMPTON / ADAM EDGTON (26) | 113.43 |
| 88 HEATHER MOTTERAM / SUSAN EMERSON (85) | 112.93 |
| 89 JAN PEACH / GEORGE LOVRECZ (131) | 112.84 |
| 90 PATRICK NEARY / WARREN DOBES (187) | 112.6 |
| 91 DAVID MCLEISH / PAULA MCLEISH (49) | 112.36 |
| 92 GREG MAYO / SHARON MAYO (52) | 112.19 |
| 93 BAL KRISHAN / HASHMAT ALI (62) | 111.2 |
| 94 PABLO LAMBARDI / ERVIN OTVOSI (14) | 111.08 |
| 95 TOM STRONG / EDDA STRONG (104) | 110.6 |
| 96 ROBERT BLACK / TANIA BLACK (149) | 110.5 |

| | | |
|------|--|--------|
| | 97 CORRIE VAN LIER / JEANNE ANDERSON (89) | 110.33 |
| | 98 GLENDA BARTER / BERNADETTE CAMPBELL (177) | 110.26 |
| | 99 ANDREW HEGEDUS / ANDREW MILL (57) | 110.08 |
| | 100 SIMON ANDREW / GWEN KING (34) | 109.96 |
| | 101 TINA STRICKLAND / MARY O'TOOLE (161) | 109.76 |
| | 102 MARK MORDO / JIM BEAN (144) | 109.56 |
| | 103 PIETER KLIFFEN / MARJORIE THOMAS (137) | 109.55 |
| | 104 SALLY MURRAY-WHITE / GEOFF WHITING (84) | 109.46 |
| | 105 JOHN KELLY / BASTIAN BOLT (103) | 109.31 |
| | 106 PELE RANKIN / GREER TUCKER (59) | 109.15 |
| | 107 STEVEN THORNE / KIRSTEN THORNE (105) | 108.36 |
| | 108 HELEN CRISP / CAROLYN ROXBURGH (175) | 108.23 |
| | 109 VERA ROWLAND / SANDRA MILNER (135) | 108.14 |
| | 110 MEG WATERWORTH / CEINY MAYBURY (184) | 107.95 |
| | 111 DENIS GRAHAME / JEANETTE GRAHAME (99) | 107.75 |
| | 112 LIZ QUITTNER / MISCHA SOLAR (86) | 107.7 |
| | 113 HEATHER GRANT / FRANK CAMPBELL (166) | 107.68 |
| | 114 LOUIS VEENSTRA / LYNNE VEENSTRA (181) | 107.53 |
| | 115 ALISON DAWSON / ELIZABETH ZELLER (160) | 107.47 |
| | 116 PATRICIA LACEY / CARMEL BOURKE (153) | 107.26 |
| | 117 CAROLA HOOGERVORST / ANDRE KORENHOF (194) | 107.2 |
| | 118 DONALD KNAGGS / PEER BACH (156) | 106.45 |
| | 119 ERIC LINDH / PATRICIA PHILLIPS (114) | 106.03 |
| | 120 MICHAEL JOHNSON / MICHAEL SIMES (33) | 105.98 |
| | 121 MRINAL DEY / IAN NAPIER (143) | 105.54 |
| | 122 WATSON ZHOU / CHARLIE LU (81) | 105.34 |
| | 123 GEOFF CHETTLE / GREG LEWIN (172) | 105.27 |
| | 124 RICHARD HILLS / ALISON FARTHING (68) | 105.2 |
| | 125 ROD DUNN / TIMOTHY STEWART (195) | 105.12 |
| | 126 JEANETTE ROUGHLEY / MARGARET BAZZAN (134) | 105.02 |
| 126= | HELEN LOWRY / BERENICE FOLKARD (43) | 105.02 |
| | 128 CRISTEL PHILP / JOAN TUCKER (188) | 104.89 |
| | 129 RONALD SMITH / ANNE SMALL (73) | 104.86 |
| | 130 JODI TUTTY / MARIANNE BOOKALLIL (30) | 104.84 |
| | 131 FIONA BALLARD / IAN PLUMMER (147) | 104.78 |
| | 132 LISA PHILLIPS / SHIRLEY PHILLIPS (106) | 104.77 |
| | 133 LINDA WILD / HELENE KOLOZS (146) | 104.65 |
| | 134 ANDREW BRAITHWAITE / SUZIE MOSES (45) | 104.21 |
| | 135 SYLVIA FOSTER / JAAN OITMAA (170) | 104.12 |
| | 136 JOHN MOTTRAM / LORRAINE SCHAAP (53) | 103.87 |
| | 137 TERRI KAY / KITTY MUNTZ (112) | 103.25 |
| | 138 HELEN STEWART / TIM O'LOUGHLIN (122) | 103.06 |
| | 139 WAYNE BURROWS / KAYLEE LEMON (93) | 102.89 |
| | 140 YOLANDA CARTER / TONI BARDON (97) | 102.69 |
| 140= | KEN DAWSON / ANDREW SLATER (75) | 102.69 |
| | 142 GRAY RENWICK / DAVID SKIPPER (24) | 102.34 |
| | 143 LOUIS KOOLEN / BARBARA GRANT (139) | 102.2 |
| | 144 PETER COX / MARGARET PISKO (167) | 102.09 |
| | 145 ADRIAN THOMPSON / BALA MANICCAVASAGAR (87) | 101.64 |
| | 146 LEONE MOFFAT / ELAINNE LEACH (116) | 101.6 |

| | | |
|------|---|--------|
| 146= | JAN TUNKS / MARION SPURRIER (82) | 101.6 |
| | 148 VALERIE SANDERSON / JOHN FRIESEN (125) | 101.39 |
| | 149 MARELLE IRVINE / JUDY KINGSTON (173) | 100.52 |
| | 150 RICHARD FOX / LIZ SCORER (121) | 99.16 |
| | 151 FREDA HADWEN / BILL REDHEAD (148) | 99.07 |
| | 152 CARMEL MARTIN / CAROLYN WOOLLEY (107) | 98.99 |
| | 153 MYONG CAMPBELL / PAUL MCGLEW (186) | 98.48 |
| | 154 HEATHER FLANDERS / ANN MELLINGS (90) | 98.38 |
| | 155 INES DAWES / DI JONES (118) | 97.59 |
| | 156 GARY HOLLANDS / SUE HOLLANDS (101) | 97.55 |
| | 157 PETER BRENNAN / JANET STRZELECKI (152) | 97.23 |
| | 158 HELEN HELLSTEN / PETER HOLLOWAY (154) | 97.22 |
| | 159 IVY LUCK / JOHN LUCK (72) | 96.8 |
| | 160 PETER LIVESEY / CHRIS DIBLEY (70) | 96.69 |
| | 161 ROBYN BARRETT / ROBYN RUDZYN (192) | 95.68 |
| | 162 PAUL EDWARDS / JAN JAY (128) | 95.56 |
| | 163 GEOFFREY THOMAS / NIKOLAS MOORE (109) | 95.36 |
| | 164 PETER BENDELSTEIN / PETER LIPTHAY (155) | 94.32 |
| | 165 DIANE MUNRO / CAROLINE GARDINER (145) | 93.66 |
| | 166 HENRIETTA HOHNEN / MALCOLM MARTIN (174) | 93.51 |
| | 167 CATE WHITTAKER / ROBERT CASE (185) | 93.29 |
| 167= | TONY MARKER / BARBARA TOOHEY (138) | 93.29 |
| | 169 LEE ANDREWS / KATHY BRIDGES (191) | 92.55 |
| | 170 BETTY MILL / VICKI TAYLOR (113) | 92.49 |
| | 171 CAROLYN MILLER / JANEEN SOLOMON (74) | 92.4 |
| | 172 FRANK VEARING / JO-ANNE HEYWOOD (178) | 91.93 |
| | 173 FRANCI HALMOS / JEAN HALL (79) | 91.62 |
| | 174 TONY FALLET / CLARE GALLAGHER (96) | 91.36 |
| | 175 ALEXANDER COOK / ROBIN HO (171) | 90.77 |
| | 176 DEB BENNETT / PAM MORGAN-KING (136) | 89.38 |
| | 177 MAHA HOENIG / SUE O'BRIEN (100) | 89.28 |
| | 178 ANDRZEJ JEZ / MARIA MORYTO (179) | 89.2 |
| | 179 FRANCES GARRICK / BRUCE DAGLISH (159) | 89.14 |
| | 180 PETER NILSSON / DEBORAH NILSSON (165) | 88.43 |
| | 181 KAYE DONALDSON / JOHN MASTERS (127) | 88.23 |
| | 182 SUSAN SCERRI / ALLAN SCERRI (164) | 87.55 |
| | 183 ROBYN SMITH / MICHAEL SMITH (176) | 86.96 |
| | 184 MICHAEL MCAULIFFE / MICHAEL RONAI (196) | 86.91 |
| | 185 KEN ANDERSON / LINDY ANDERSON (182) | 86.76 |
| | 186 ANNE BATES / SUE ALLEN (132) | 86.48 |
| | 187 ANNA ST CLAIR / JENNIE RENNIE (92) | 85.37 |
| | 188 ERIC TAYLOR / HELEN TAYLOR (151) | 84.74 |
| | 189 JAN DOONER / RON LORRAWAY (60) | 83.9 |
| | 190 ROBYN GRIFFITHS / MARION BUCENS (157) | 83.21 |
| | 191 GWEN GRAY / CLAIRE WEHNER (162) | 82.4 |
| | 192 WAYNE HOUGHTON / CHRISTINE HOUGHTON (126) | 82.26 |
| | 193 JAN MALINAS / CONNIE SCHOUTROP (98) | 81.29 |
| | 194 MICHAEL STONEMAN / VAL ROLAND (140) | 77.26 |
| | 195 JOHN CLIFTON / DOMINIC KWOK (119) | 77.23 |
| | 196 CAROLE MCDONALD / DOROTHY BEIL (110) | 76.56 |

| | | |
|-----|---|-------|
| 197 | MEGAN MCGLASHAN / DESMOND MCGLASHAN (150) | 76.43 |
| 198 | PAMELA SMITH / JUDITH SELLECK (158) | 75.56 |
| 199 | DONALD CARTWRIGHT / LIZ CARTWRIGHT (198) | 74.05 |
| 200 | NEVILLE FARRELL / PAMELA LAWRENCE (123) | 73.38 |
| 201 | ALBERT JOH KELLY / DAVID CLARKSON (199) | 73.35 |
| 202 | MIRACA GROSS / JOHN GROSS (189) | 62.99 |

Penline National 500 Swiss Pairs

| Place | Pair Names | VPs |
|-------|--|--------|
| 1 | KATHY GILBERT / MAX GILBERT (30) | 145.98 |
| 2 | RICHARD PRICKETT / PATRICIA AFFLICK (10) | 142.5 |
| 3 | HENRY CHU / SIAMAK PARSANEJAD (38) | 140.85 |
| 4 | LEX RANKE / JACK ROHDE (3) | 138.02 |
| 5 | ALEXANDER HEWAT / JOHN DONOVAN (4) | 137.21 |
| 6 | MICHAEL RANGLES / BENJAMIN SADLER (77) | 134.63 |
| 7 | TERRY DUNNE / DENIS KRISTANDA (75) | 133.3 |
| 8 | JACK COLWELL / COLLEEN FOGARTY (48) | 132.28 |
| 9 | RHONDA THORPE / ROBERT HURST (18) | 129.72 |
| 10 | KEITH MITCHELL / LESLEY GUNSON (29) | 129.18 |
| 11 | ALAN DAVIES / VIVIEN ELDRIDGE (1) | 128.66 |
| 12 | JAMALUDDIN RAYANI / PARVEEN RAYANI (73) | 127.8 |
| 13 | GEORGE LUPUL / ELLA LUPUL (56) | 127.44 |
| 14 | ROSEMARY POLYA / JOLANTA TERLECKA (66) | 127.07 |
| 15 | MARGARET KENNY / ELIZABETH NEIL (59) | 125.82 |
| 16 | RUTH NEILD / COLIN BALE (44) | 125.43 |
| 17 | HENRY JOSLING / STEPHEN CURTIS (26) | 124.71 |
| 18 | ALLAN PIKE / ARTHUR BRAGG (51) | 124.06 |
| 19 | GREG NICHOLSON / JEAN BARBOUR (5) | 123.99 |
| 20 | ANNE CLARKE / RICHARD CLARKE (50) | 123.77 |
| 21 | ANNE REILLY / JACK CARSON (7) | 122.91 |
| 22 | DONNA CROSSAN-PEACOCK / LINDSAY SCANDRETT (68) | 122.74 |
| 23 | DIANA ELLIS / CHRIS HANNAN (11) | 121.57 |
| 24 | SUSANNE GAMMON / DEANA WILSON (25) | 121.15 |
| 25 | JENNY BUCKLEY / MARTIN JOHNSON (22) | 120.77 |
| 26 | SUSAN NELAN / BRUCE NELAN (35) | 120.62 |
| 27 | KARL BUCHMANN / JILL BUCHMANN (64) | 120 |
| 28 | PETER BARDOS / ANAND BAPAT (58) | 119.92 |
| 29 | JENNETTE ROSETTA / BERNARD DAVIDSON (54) | 118.96 |
| 30 | IAN MACLAREN / ELAINE DIGNAN (2) | 118.25 |
| 31 | DENNIS RAYMOND / ERNIE NEWMAN (16) | 116.75 |
| 32 | LILLIAN LESUEUR / BRONWYN BOEHM (69) | 116.22 |
| 33 | LYDIA ADAMS / BILL FORBES (40) | 116.14 |
| 34 | JOANNA TENNYSON / JENNIFER BANDY (6) | 115.66 |
| 35 | VINCE CARIOLA / RICHARD MASSEY (19) | 115.41 |
| 36 | NEIL STRUTTON / BARBARA KENT (14) | 115.25 |
| 37 | JOHN HUGHES / KRISTIN HUGHES (15) | 113.52 |
| 38 | GEOFF HAYES / SUSAN RYRIE (78) | 113.4 |
| 39 | JESSICA CHEW / GWYNEIRA BRAHMA (65) | 113.29 |
| 40 | JACQUELINE GRUSZKA / STUART GRIGG (57) | 112.16 |

| | |
|--|--------|
| 41 CHRIS FADER / RICHARD BODELL (39) | 111.55 |
| 42 NAOMI WAIZER / EDWARD TRUSCOTT (31) | 111.21 |
| 43 LISA DUNPHY / MARIS TAYLOR (52) | 110.18 |
| 44 GILL TIDEY / SALLY BARBER (71) | 110.11 |
| 45 JOHN ROGERS / MARGARET ROGERS (17) | 109.65 |
| 46 BARBARA ANDERSON / JANET BELL (34) | 108.07 |
| 47 HELEN RIAL / EDITH UNDERWOOD (32) | 107.24 |
| 48 DEBORAH PENNEY / DI FALLON (41) | 106.8 |
| 49 CAROLYN LEACH / BRIAN LEACH (12) | 106.23 |
| 50 JOHN ELICH / GABRIELLE ELICH (55) | 105.65 |
| 51 KATHY CLIFT / MALCOLM CLIFT (28) | 105.05 |
| 52 CATHERINE ELSE / KATHRYN HAWKE (49) | 104.21 |
| 53 MAURICE RIPLEY / MICHAEL BOX (42) | 103.39 |
| 54 ROBERT WARD / ALEX PENKLIS (61) | 102.51 |
| 55 HEATH COOK / BARRY COOK (36) | 102.4 |
| 56 ERIC BAKER / BRIAN GLOVER (46) | 101.96 |
| 57 ROBIN STEINHARDT / HELEN CHAMBERLIN (9) | 101.45 |
| 58 WAYNE CARROLL / FRAN CARROLL (13) | 99.18 |
| 59 PATRICIA MCDONALD / BRUCE CHAPMAN (72) | 99.04 |
| 60 JOSEPH FITZPATRICK / WHALLEY ROBIN (27) | 98.83 |
| 61 JANET REYNOLDS / TERRI HENDERSON (47) | 98.68 |
| 62 DENISE O'REGAN / ELLEN DUGGAN (33) | 98.5 |
| 63 FAYE MORRIS / SALLY GRAHAM (23) | 98.26 |
| 64 ANNTHEA MATHESON / ROBBIE CARMICHAEL (82) | 97.25 |
| 65 BARRY FOSTER / HOPE TOMLINSON (8) | 97.22 |
| 66 ALAN BOYCE / MONICA PRITCHARD (24) | 96.64 |
| 67 SHARON CARVER / BILL BISHOP (67) | 95.62 |
| 68 ARCHIBALD FRASER / GRETA DAVIS (53) | 94.32 |
| 69 DENISE ROGERS / LEE ROGERS (20) | 93.14 |
| 70 JO KING / MARY PROWSE (62) | 92.75 |
| 71 GUY DILLON / HOLLY DILLON (79) | 92.32 |
| 72 ROB CROWDY / LYN RAINFOREST (81) | 90.84 |
| 73 KEVIN CARUANA / CAROLINE DAWSON (76) | 89.68 |
| 74 MARGARET GERBER / WOLFGANG GERBER (63) | 88.05 |
| 75 JEANETTE WEAVER / LORAINNE NEVILLE (43) | 87.12 |
| 76 JOE HANNA / SUSAN HARRISON (45) | 84.46 |
| 77 CHERYL HENKE / HELEN BARNES (74) | 84.34 |
| 78 JANET WILLIS / MARGARET PHIPPEN (21) | 79.76 |
| 79 BRUCE WORTHINGTON / ANNE SYMONS (37) | 78.57 |
| 80 ODETTE MAYNE / LEE EGERTON (70) | 76.89 |
| 81 PATRICIA EVANS / ROSLYN HINTON (60) | 68.91 |
| 82 JEANETTE MCCORRISTON / JOYCE HOLMES (80) | 68.01 |

getwinesdirect.com
1300 559 463

is pleased to offer
great wine
to ABF members



with a 7% discount
off already
discounted prices



Get Wines Direct is a partner of the Australian Bridge Federation and one of the Australian Wine Industry's largest independently owned online retailers.

Along with offering every bridge club member around Australia a 7% discount, Get Wines Direct are giving clubs the chance to purchase at the same discounted rate.

Furthermore with every wine purchase you will be helping support your state and national bridge association. You won't beat that great opening bid!

To access your discount while supporting your bridge association simply follow the steps outlined below. So many reasons to spread the word to your fellow members and friends!

1. Visit www.getwinesdirect.com and select your products
2. Proceed to checkout (My Order)
3. Get the promotion code for your region from the ABF website. Enter this code
4. If you are a current member, enter your details, if not, sign up.
5. Confirm your details and finalise your order
6. Allow 7-10 working days for your order to arrive and enjoy!

If you prefer to speak to one of our lovely call centre Sales Consultants phone 1300 559 463, quote your promotion code and we will ensure your order is submitted and delivered as soon as possible!

*Have a look at our
new website!*

CONNECT with us

Australia's No. 1 Online
Wine Retailer!

getwinesdirect.com
1300 559 463

Tasting Room: 157-161 Burnley St Richmond Victoria. Mon-Tues 10-6, Wed-Fri 10-6.30, Sat-Sun 10-5. A flat fee of \$9.00 per carton for delivery Australia-wide. Available whilst stocks last. WARNING: Under the Liquor Control Reform Act 1998 it is an offence: • To supply alcohol to a person under the age of 18 years (Penalty exceeds \$8,000) • For a person under the age of 18 years to purchase or receive liquor (Penalty exceeds \$700) • Liquor Licence No. 32054699 & 36065595.



2015 Summer Festival Courtesy Bus Route

| Approximate Pickup Time | Accommodation | Address |
|-------------------------|---|---|
| 8.30am | Forrest Hotel and Apartments Medina Apartments Meridien Apartments Pinnacle apartments Hyatt | Forrest Giles Street, Kingston Giles Street, Kingston 11 Ovens St, Kingston Commonwealth Avenue, Barton |
| 8.50am | Rydges Waldorf Apartments Mecure Hotel (Olims) Mercure Ap'ts, Capital Executive Medina Apartments Rydges Dropoff Liversidge Court University House Rydges | Drop off City Cnr Limestone Ave & Ainslie Ave 108 Northbourne Ave 74 Northbourne Ave 1 London Crt Liversidge St Cnr Liversidge St & Balmain Cres, ANU, Acton Drop Off |

The courtesy Bus will leave the first accommodation site 90 minutes before play begins and will return after play. It is **approximately** 5 minutes between stops.

All Times are approximate



SCHEDULE OF ACTIVITIES



| Activity | When | Where | Who | Comments |
|--|---|---------------------------------|---------------------------------|---|
|  Free wine tasting from our sponsor – Get Wines Direct | Monday 19 January | Mezzanine Floor | Everyone welcome | <ul style="list-style-type: none"> Sample delicious wines from our National sponsor. Wine orders can be taken by the Get Wines Direct representative – delivered to your home or office. Fabulous prices – further discounted for members of ABF affiliated clubs. |
| Celebrity Speaker Ron Klinger <i>(Extended use of Transfers in Modern Bidding)</i> | 9.00 – 9.40 am Tuesday 20 January | Eureka Room Ground Floor | Everyone welcome | Gold coin donation – proceeds to Neurological Research at the Prince Charles Hospital, Brisbane |
| Public forum – ABF Australian Team Uniforms | Lunch break Tuesday 20 January | Studio 2 & 3 Mezzanine Floor | Women, Seniors and Open players | An opportunity to contribute to the National uniform discussion. |
| Seminar – Guidance on dealing with difficult and disruptive players | 8.30 am Wednesday 21 January | Studio 2 & 3 Mezzanine Floor | Directors and event organisers | Presenter : Melanie Fischer Former Deputy CEO, Food Standards Australia & NZ |
| Celebrity Speaker Sartaj Hans <i>(How to Play against the Top Teams)</i> | 9.00 – 9.40 am Wednesday 21 January | Eureka Room Ground Floor | Everyone welcome | Gold coin donation – proceeds to Neurological Research at the Prince Charles Hospital, Brisbane |
| Celebrity Speaker Matt Mullamphy <i>(Slam Bidding)</i> | 8.30 – 9.10 am Thursday 22 January | Eureka Room Ground Floor | Everyone welcome | Gold coin donation – proceeds to Neurological Research at the Prince Charles Hospital, Brisbane |

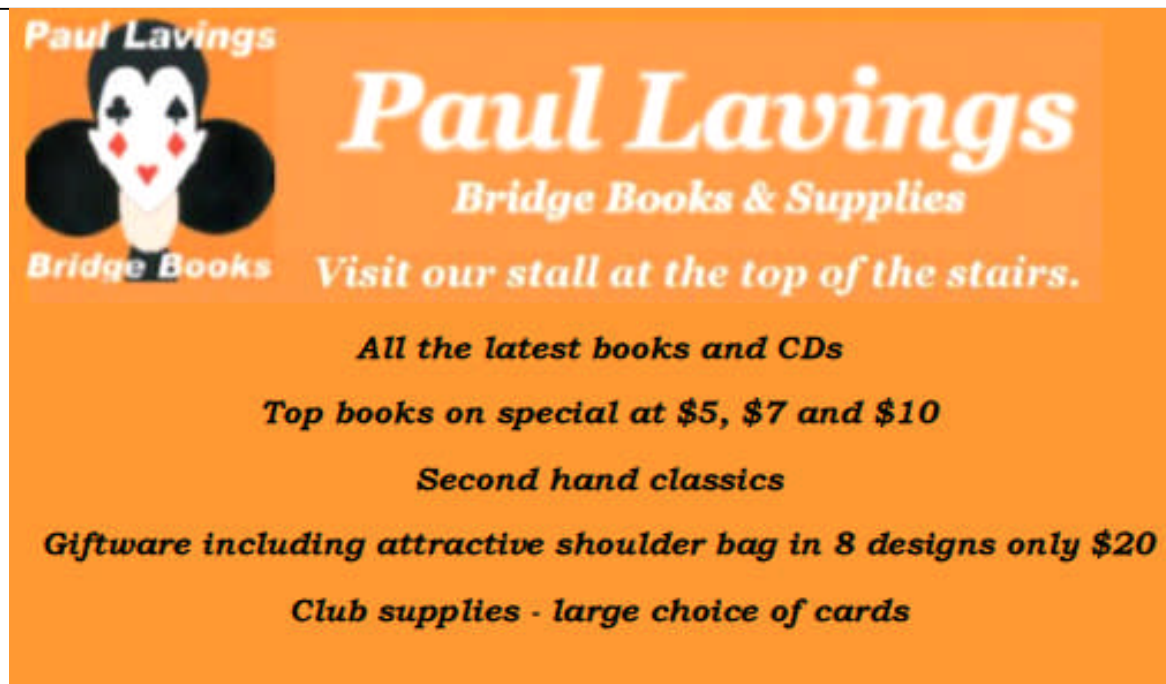

Paul Lavings

Paul Lavings
Bridge Books & Supplies
Bridge Books Visit our stall at the top of the stairs.
All the latest books and CDs
Top books on special at \$5, \$7 and \$10
Second hand classics
Giftware including attractive shoulder bag in 8 designs only \$20
Club supplies - large choice of cards