



N.O.T. News 1

Canberra, Tuesday January 12th 2010

Welcome to the 2010 Summer Festival of Bridge.

2010 brings the Summer Festival into the electronic age of bridge with the introduction of Bridgemates to all events. This innovation will allow players to see contracts, leads and results of boards from all other tables and matches.

Once again the venue for the Summer Festival is the National Convention Centre. The National Convention Centre will have catering facilities in the foyer just outside the playing area. The Summer Festival also provides a free shuttle bus to help move players to and from their accommodation. This free shuttle bus route is included in this bulletin and on the notice board. If you have any questions during the Summer Festival, the Summer Festival staff will be happy to help.

Enjoy the 2010 Summer Festival of Bridge and happy bridging

Sean Mullamphy

Convener

Session Times – Wednesday		
11am	3pm	8pm
Session Times – Thursday		
10 am	1.30pm	4.30pm



Bridge Scoring in the 21st Century – Player Obligations

At the 2010 Summer Festival, each table will be equipped with an electronic scoring unit. Some of you may have seen and used these before, some of you will have seen a precursor and for some of you this will be quite new.

1. The units are user-friendly and you will quickly learn how to use them.
2. **Initialise units for the match.** Listen while the Director explains how to activate the units and update them for the match about to be played. The input required will be the table number and the identity codes for the four players sitting at the table.
3. **N or S enter the score.** At the conclusion of each board, either N or S should input
 - board number,
 - contract,
 - declarer,
 - opening lead and
 - number of tricks made.
4. **E or W check the score.** The unit will generate a score which E or W MUST check and acknowledge by pressing the appropriate button.
5. **At the end of the match.** The unit will continually indicate the number of boards yet to be played. At the conclusion of the match, THIS MUST BE ZERO. If not, call a Director to ascertain which board has not been scored on the unit.
6. **Paper score slip.** For the 2010 Summer Festival, you will ALSO be required to fill out and submit an AGREED result slip (as in previous years) showing the imps scored by each team and the difference between them.
7. **Draw for the next round.** For the purposes of drawing opponents for each subsequent round, the scores

input electronically to the scoring units will be used.

8. **Scoring Errors.** Checking of results will take two independent forms:
 - Scores produced by the electronic input will be compared with those on the paper slips. If there is a discrepancy the numbers of the teams involved will be displayed with a request that a representative of each team consult a Director to facilitate a resolution. This will take place either before the next match or at the conclusion of the next match (for a 30 minute period only).
 - During the next round, each team will be provided with a print out of the results from the electronic units for the match just completed, and the overall match result. You should check that the results correspond with your personal record. If there is a discrepancy, report the error (preferably agreed by your opponents) to a Director during the correction period of 30 minutes after the conclusion of the current match.
9. For the integrity of the event it is important that errors in scoring be corrected. Towards the end of any qualifying event it is vital that the number of scoring errors is kept to an absolute minimum.

If you wish to email material for NOTNews, the address is

alan@taylor.co.nz

The 0 is a zero not a letter

Summer Festival Bus Route

- Hyatt Hotel - Commonwealth Ave - **Pickup is at back of Hotel 60minutes before 1st Session**
- NCC
- Olims Hotel –Cnr Ainslie & Limestone Ave
50 minutes before 1st Session
- Fenner Hall
45 minutes before 1st Session
- Rex Motel
- Capital Executive Apartments .
Pickup at Marque Hotel
- Quality Suites Clifton on Northbourne – -
Pickup at Marque Hotel 40 minutes before 1st session
- Medina Apartments
- NCC
- Liversidge Court, ANU
35 minutes before 1st Session
- University House - Pickup on Liversidge Street
- Rydges Lakeside Hotel
- Capitol Tower Apartments (pickup at Rydges Lakeside)
- Novotel on Northbourne
30 minutes before 1st Session
- NCC
- Hyatt Hotel - Commonwealth Ave - **Pickup is at back of Hotel 15minutes before 1st Session**
- NCC

If you would like **Another Accommodation Location Added** to the route please email

The Convener at not@abf.com.au .
Pick-up times are approximate

Tim Bourke's Problem

1. UNEXPECTED

Dealer South. Both Vul.

NORTH
 ♠8 5 3 2
 ♥6 4 2
 ♦A Q 6 5
 ♣A 6

SOUTH

♠A Q 4
 ♥A K Q
 ♦K J
 ♣K Q 8 4 2

West	North	East	South
			2♣
Pass	2♦	Pass	2NT
Pass	6NT	All pass	

How would you play 6NT after West leads the jack of hearts?

Deceptive Appearances

From most of the hands that follow, the reader would no doubt assume that Hashmat Ali and Peter Kahler had a comfortable win over Sara Tischler and Bobby Richman in the sixth round of the Seniors Last Train. In fact, Bobby and Sara ran out with a 22-8 victory but somehow many of their good boards didn't seem very interesting. They started with board 23 and Peter was quickly in 3NT on the layout below.

		♠ K 10 9 7 4		
		♥ J 10 7 6		
		♦ 8 5		
		♣ K 2		
♠ 2				♠ A J 8
♥ Q 9 8				♥ A 5 4
♦ A Q J 7 6	W		E	♦ K 10 9 3
♣ Q 8 6 3				♣ J 7 4
		♠ Q 6 5 3		
		♥ K 3 2		
		♦ 4 2		
		♣ A 10 9 5		
SLT 6/24		Dealer S	Vul All	

Bobby opened 2♠ which was quickly brushed aside. Deepfinesse has only 7 tricks available to EW but ...

A spade was led to the King and Ace and the ♦10 was cashed. Three more rounds of

diamonds followed and then a small club was led, taken by North with the King to leave

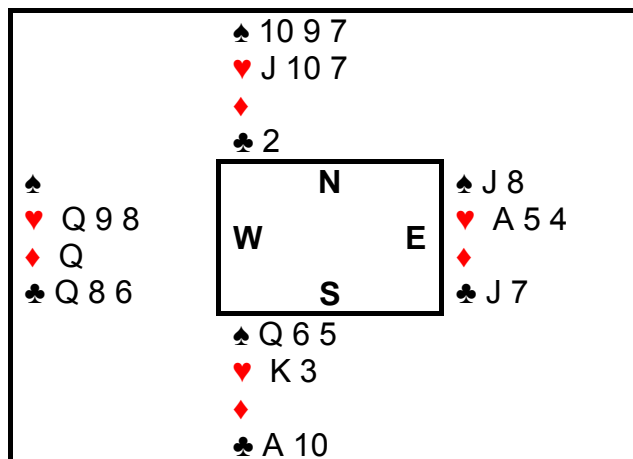

Obviously a spade switch now beats 3NT in some comfort but North switched to the ♥10. Declarer let this go past and South scored the King. The ♠Q was cashed and then a heart went to the 9, Jack and Ace and declarer suddenly found himself with 9 tricks.

Onto the next and it was Hashmat's turn to try and outdo Deepfinesse who this time, had 8 tricks available in no trumps.

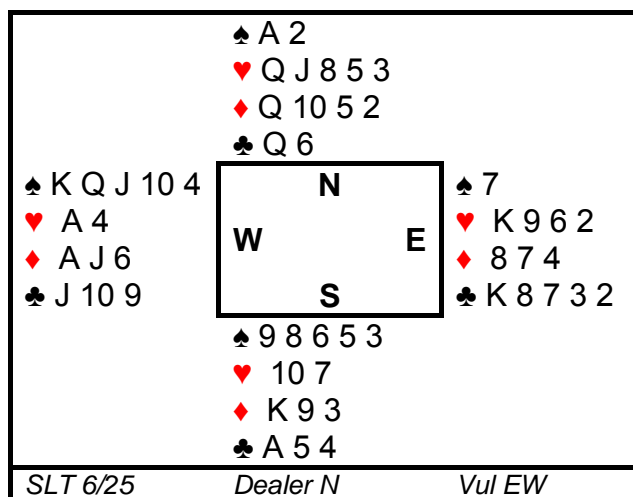

North led the ♥5 and this collected the 9, 10 and Ace. The ♣J was passed around and then the ♠10 was covered by North and East but ducked by South. Declarer played dummy's spade and North took the King with his Ace to switch to the ♥Q. Hashmat ducked this to bring about

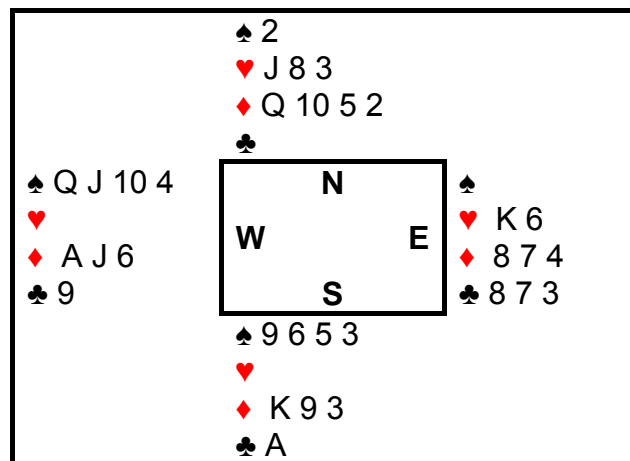

A diamond switch now would lead to two off but North continued the Jack of hearts and South chose the discard of a small spade but now declarer's spades were all good and he had 9 tricks.

Then, two boards later South faced a bidding problem. You hold, at equal nil,

♠ 4 3 ♥ J 10 9 4 3 ♦ 8 6 ♣ Q J 6 3

You pass and Iho opens 2♥ - weak in spades. Partner doubles and rho bids 4♠. Back to partner who doubles again and it's your turn.

South chose not unreasonably to bid 5♥. This was not a pretty contract on

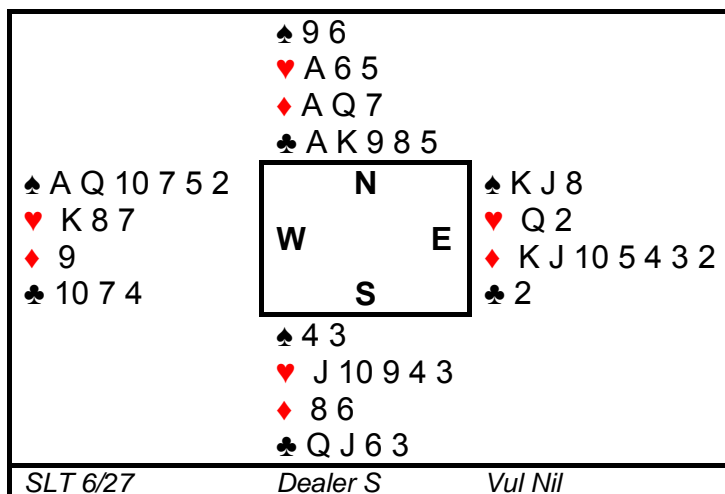

A defensive cross-ruff led to 4 down but happily no-one had doubled so -200 was a pick-up against the spade game.

A few boards later and it was minus 4 déjà vu all over again; though this time one would have to have less sympathy for South.

You hold, again at nil,

♠ Q 8 ♥ K Q 9 7 ♦ 4 2 ♣ A K 10 8 6

You choose to open 1NT after a pass on your right. Next hand doubles and partner bids 3♦. In response to East's query you explain that this is to play. Your bid?

No, I thought not. South, however, tried the effect of 3♥. Not a triumph on

	♠		
	♥	Q 8 7 6 3	
	♦	8 5 2	
	♣	K 10 9 7 6	
♠ 10 9 3		<div style="display: flex; justify-content: space-between;"> N </div> <div style="display: flex; justify-content: space-between;"> W E </div> <div style="display: flex; justify-content: center; margin-top: 10px;"> S </div>	♠ A K Q 4 2
♥ J 10 5			♥ A K
♦ A J 7 4			♦ K Q 10 3
♣ A J 2			♣ Q 3
	♠	J 8 7 6 5	
	♥	9 4 2	
	♦	9 6	
	♣	8 5 4	
SLT 6/18		Dealer E	Vul NS

Any other suit led would see declarer lose a trick in each black suit but the success of the ♠10 made twelve tricks.

Then Hashmat and Peter had a strange looking auction before declarer lost his way in the end game.

	♠	10 5 3	
	♥	10 2	
	♦	A 10 8 7 6 3	
	♣	J 2	
♠ A K J		<div style="display: flex; justify-content: space-between;"> N </div> <div style="display: flex; justify-content: space-between;"> W E </div> <div style="display: flex; justify-content: center; margin-top: 10px;"> S </div>	♠ 9 7 5 4 2
♥ A J 5 4			♥ 8 6 3
♦ Q 5			♦ K J 9
♣ Q 9 7 5			♣ 4 3
	♠	Q 8	
	♥	K Q 9 7	
	♦	4 2	
	♣	A K 10 8 6	
SLT 6/30		Dealer N	Vul Nil

3♦ would certainly have been cheaper but once again nobody doubled so it didn't hurt too much.

Then another lead problem for South who held

♠ J 8 7 6 5 ♥ 9 4 2 ♦ 9 6 ♣ 8 5 4

At unfavourable, the auction was

West	North	East	South
		2♣	P
2♦	P	2NT	P
6NT	End		

2♣ was Acolish and 2♦ was waiting.

Your lead? South chose a small spade and it was all over.

	♠	J 6 4 2	
	♥	A K 10 2	
	♦	A 10 7	
	♣	8 5	
♠ K 10 7		<div style="display: flex; justify-content: space-between;"> N </div> <div style="display: flex; justify-content: space-between;"> W E </div> <div style="display: flex; justify-content: center; margin-top: 10px;"> S </div>	♠ A Q 8 5 3
♥ Q 9			♥ 8 4
♦ J 4			♦ K Q 9 8 3
♣ A Q J 9 6 4			♣ K
	♠	9	
	♥	J 7 6 5 3	
	♦	6 5 2	
	♣	10 7 3 2	
SLT 6/19		Dealer S	Vul EW

South passed and West opened 1♣. North overcalled 1♥ and East doubled. South pushed with 2♥ and West repeated his clubs. East cued 3♥ and West repeated clubs. East now tried his luck with 4♠ and there they rested.

A heart was led to North's King and the Ace was cashed. The Ace of diamonds, on which declarer dropped the Queen, provided the defensive "book". A ruff/sluff was now conceded and declarer played two rounds of trumps to get the bad news. He switched to clubs, overtaking the King with

the Ace, to cash the Queen. All this brought about this rather interesting end position.

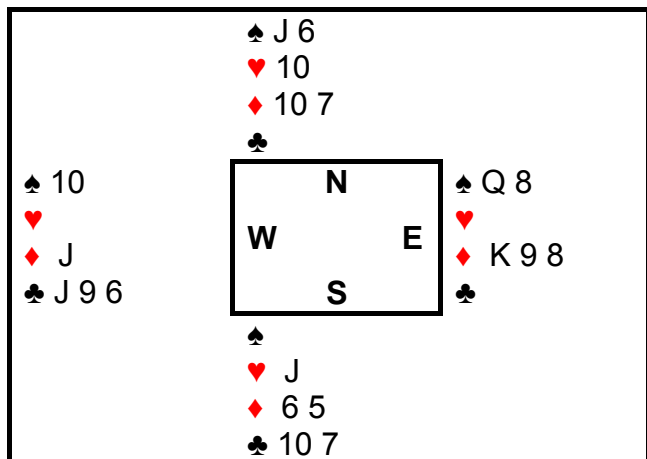

The way to succeed from here is to lead the ♦J and overtake it. A diamond ruff back to table establishes East's 9 and sets up a trump coup position against North.

If you play the ♣J first then North ruffs with the Jack and now there is no way to five tricks.

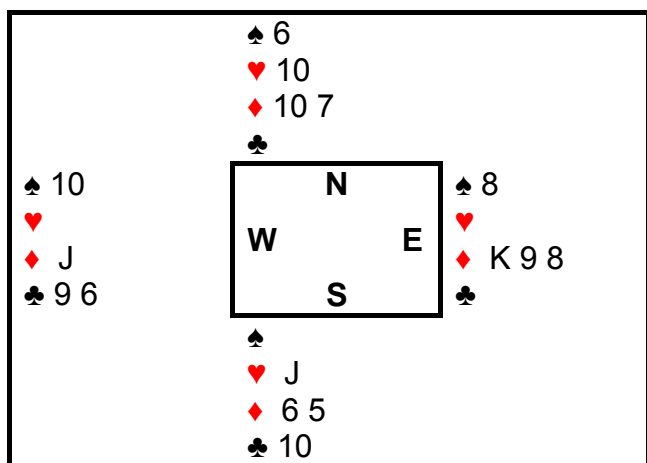

If West draws North's trump, then a minor card will have to be conceded. If, instead, a diamond is ruffed then North is going to score the trump or South the club depending on which method of going down declarer chooses.

Tim Bourke's Problem – Solution

This was originally played in a local teams match. The declarer at one table believed he was very unlucky to go down. He took the heart lead, cashed the king and jack of diamonds and crossed to the ace of clubs. As there was no other entry to dummy, he played the ace and queen of diamonds, discarding his two potential losers in spades. Next, he played the king and queen of clubs revealing a 4-2 break.

Unfortunately the full deal was:

♠ 8 5 3 2	♠ 10 7
♥ 6 4 2	♥ 8 3
♦ A Q 6 5	♦ 9 8 7 3 2
♣ A 6	♣ J 10 7 5
♠ K J 9 6	♠ A Q 4
♥ J 10 9 7 5	♥ A K Q
♦ 10 4	♦ K J
♣ 9 3	♣ K Q 8 4 2

Declarer now conceded a club trick but East had a diamond to cash for the setting trick.

While the first declarer was unlucky that East had five diamonds and four clubs, the other declarer unblocked the diamonds then played a low club from both hands at trick four. He was able to win the return, cross to the club ace and make a spade, three hearts, four diamonds and four clubs.

Summer Festival

Senior's Last Train Final - 2010

Place	Name	Score
1	J Pettitt, F Power	140
2	G Bailey, K Bailey	139
3	D Grahame, J Grahame	136
4	G Rippon, T Davis	134
5	S Tishler, B Richman	132
6	M Solar, G Bilski	128
7	E Adams, E Chadwick	127
8	P Kahler, H Ali	126
9	R Douglas, D Vaughan	125
10	L Moses, R Touton	124
11	J Brockwell, A Thompson	122
12	A Scerri, S Scerri	120
13	L Van Der Hor, P Butcher	118
14	R Gallus, D McLeish	118
15	J Ashworth, V Brockwell	117
16	M Rhodes, R Rhodes	116
17	M Watts, T Hutton	115
18	G Finikiotis, G Lane	115
19	K Smith, F Thompson	113
20	A Meydan, T Strong	92
21	J Bean, G Liepins	90
22	B Mill, A Hamilton	90

Women's Last Train Final - 2010

Place	Name	Score
1	F Beale, D Smart	155
2	N Djurovic, P Evans	145
3	E Havas, P Schroor	133
4	M Bourke, P McLeish	133
5	M Chadwick, T Sharp	129
6	L Ma, S Coleman	123
7	C Miller, J Solomon	121
8	A Pettigrew, A Stephens	121
9	H Lowry, B Folkard	118
10	A Farthing, J Kahler	118
11	R Thorpe, V Carmody	109
12	E Grieve, L Inglis	109
13	C Combes, R Liepins	106
14	C Ritter, E Tewes	103
15	G Gray, M Campbell	101

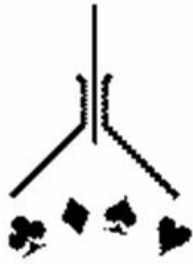

MASTERPIECES FROM PARIS

During the Summer Festival of Bridge the National Gallery in Canberra is presenting the "Masterpieces from Paris" exhibition. This exhibition will not be going to any other gallery in Australia.

The Summer Festival has organised a private viewing on Thursday evening 14th January and Wednesday evening 20th January for bridge players and their family and friends. The cost per person is \$60.

This is your opportunity to see a spectacular exhibition without the hustle and bustle of crowds and at a time convenient to bridge players attending the Summer Festival.

Tickets must be purchased in advance and are available from the information desk at the Convention Centre during the Summer Festival of Bridge.

THURSDAY 14 JANUARY 8pm – 10pm

WEDNESDAY 20 JANUARY 8pm – 10pm

Cost \$60 per person

This premium price lets you avoid lengthy queues and allows you to view these masterpieces in a much smaller group.

Telephone enquiries: Sean Mullamphy 040 150 9616